

## 1. Cleaning the Main Unit

1. Clean the main unit with a cloth dampened with hypochlorite water (concentration: 100 ppm), which can be used as cleaning solution for all parts of the operating microscope, except the lens.
2. Wipe off the hypochlorite water using a dry cloth. Leaving residual hypochlorite water on the unit can cause rusting and paint peeling.
3. Cleaning materials that may be used other than hypochlorite water (concentration: 100 ppm)
  - 70% ethanol concentration
  - 50% Isopropyl alcohol concentrationAlcohol-based cleaning materials should not be used on rubber and plastic parts, as they have a negative impact, causing them to deteriorate.

### Warning





Do not use any organic solvents (thinner, benzene, acetone, toluene, ethyl acetate, etc.) or bleaching agents as these may present a fire hazard or cause an electric shock, and may also erode plastic and painted parts.

- Keep liquids and chemical substances away from the internal areas of the equipment, as these can cause a malfunction or electric shock.
- Clean the outer surface of the optical parts (eyepieces, objective lens) only when necessary and follow the lens cleaning instructions below.

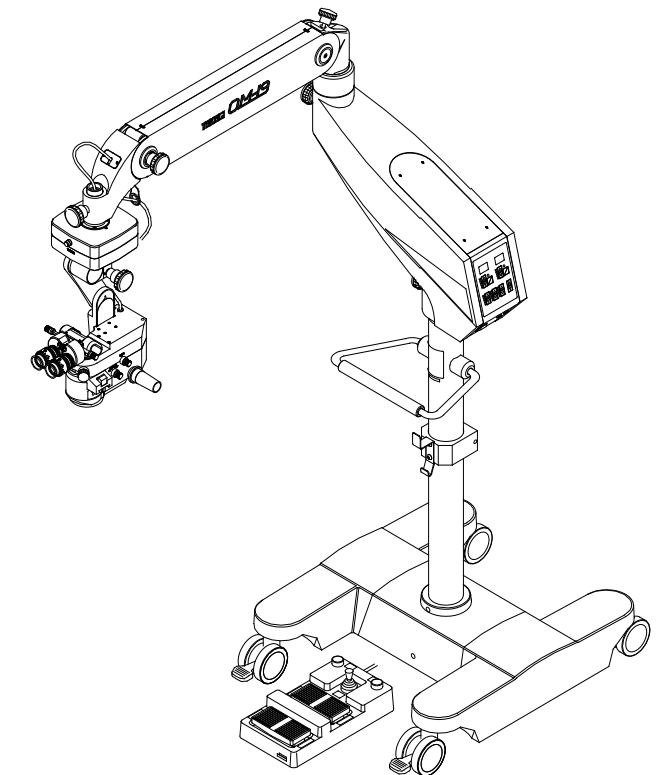
4. Sterilizable caps for knobs, switches and handles are supplied with the main unit as accessories for the operating microscope.

- Use high-pressure steam sterilization (autoclave) or ethylene oxide gas (EOG) to sterilize the caps.



			
(Z01019) 18 pcs.	(O09079) 9 pcs.	(O06111) 6 pcs.	(O04065) 15 pcs.

\*Parts number may vary depending on the model.

## 2. Cleaning the Lens

1. In cases when disinfection is not required and also prior to disinfection, remove dust from the optical surfaces using a squeeze blower or a clean, grease-free brush.
2. For cleaning that does not require disinfection, use a soft paper or cloth such as a tissue moistened with a commercially available lens cleaning solution to clean the lens part. Use a neutral solvent that contains surfactants and alcohol as a lens cleaning solution. An effective means of preventing lens fogging is to use anti-fogging agents sold at opticians, etc.

Although anti-fogging agents are not guaranteed to prevent fogging of eyepiece optics, they are effective in cleaning the eyepiece and protecting it from dirt, grease, dust and fingerprints, etc.

3. When disinfecting the lens use a cleaning fluid with a 60-70% alcohol concentration.

**⚠ Warning**  
Surface damage can be caused by use of wrong disinfectants!  
Clean using the recommended method described above.

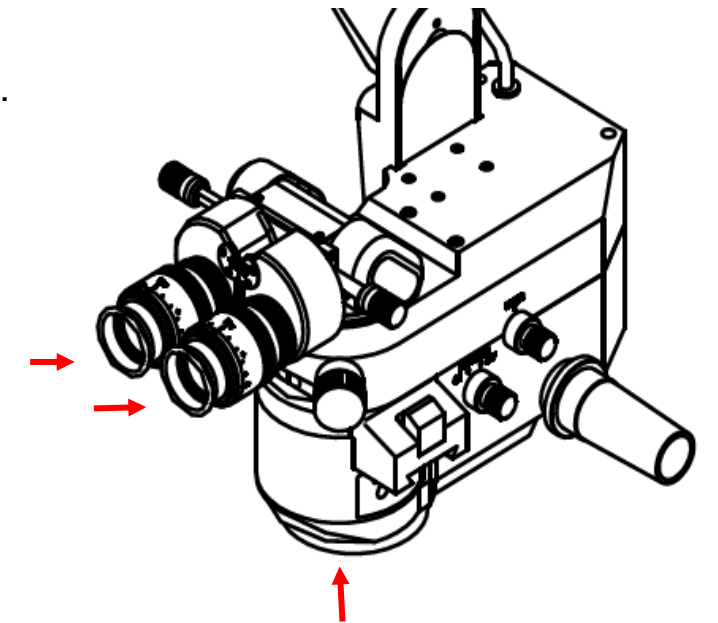

## 3. Warning when not in use

Dust can cause equipment to malfunction if it penetrates internal optical systems. Take the following measures when not using the operating microscope to prevent dust contamination.

- Do not leave the unit with the objective lens removed for long periods.
- When not in use cover with the dust covers supplied with operating microscope parts and accessories.

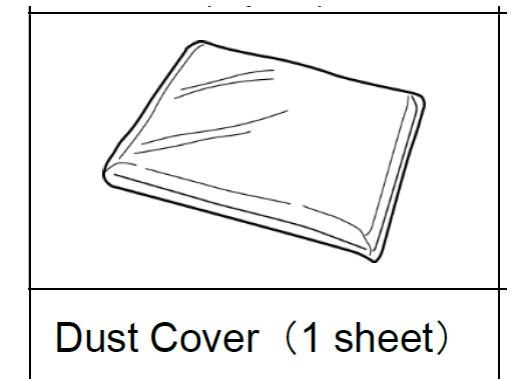

[www.takagi-j.com](http://www.takagi-j.com)

---

**For The Americas, Asia-Pacific & Middle East**  
**TAKAGI SEIKO CO. LTD.**

330-2 Iwafune  
Nakano City  
Nagano Prefecture  
383-8585  
Japan

+81 (0)269-22-4511

[www.takagieurope.com](http://www.takagieurope.com)

---

**For Europe & Africa**  
**Takagi Ophthalmic Instruments Europe Ltd**

Citylabs 1.0  
Nelson Street  
Manchester  
M13 9NQ  
United Kingdom

+44 (0)161 273 6330



*Serving Your Vision*

J(OMCG)EN Rev.0